

Liquid Ring Vacuum Pumps

VHC series

Two-stage pumps in base plate version

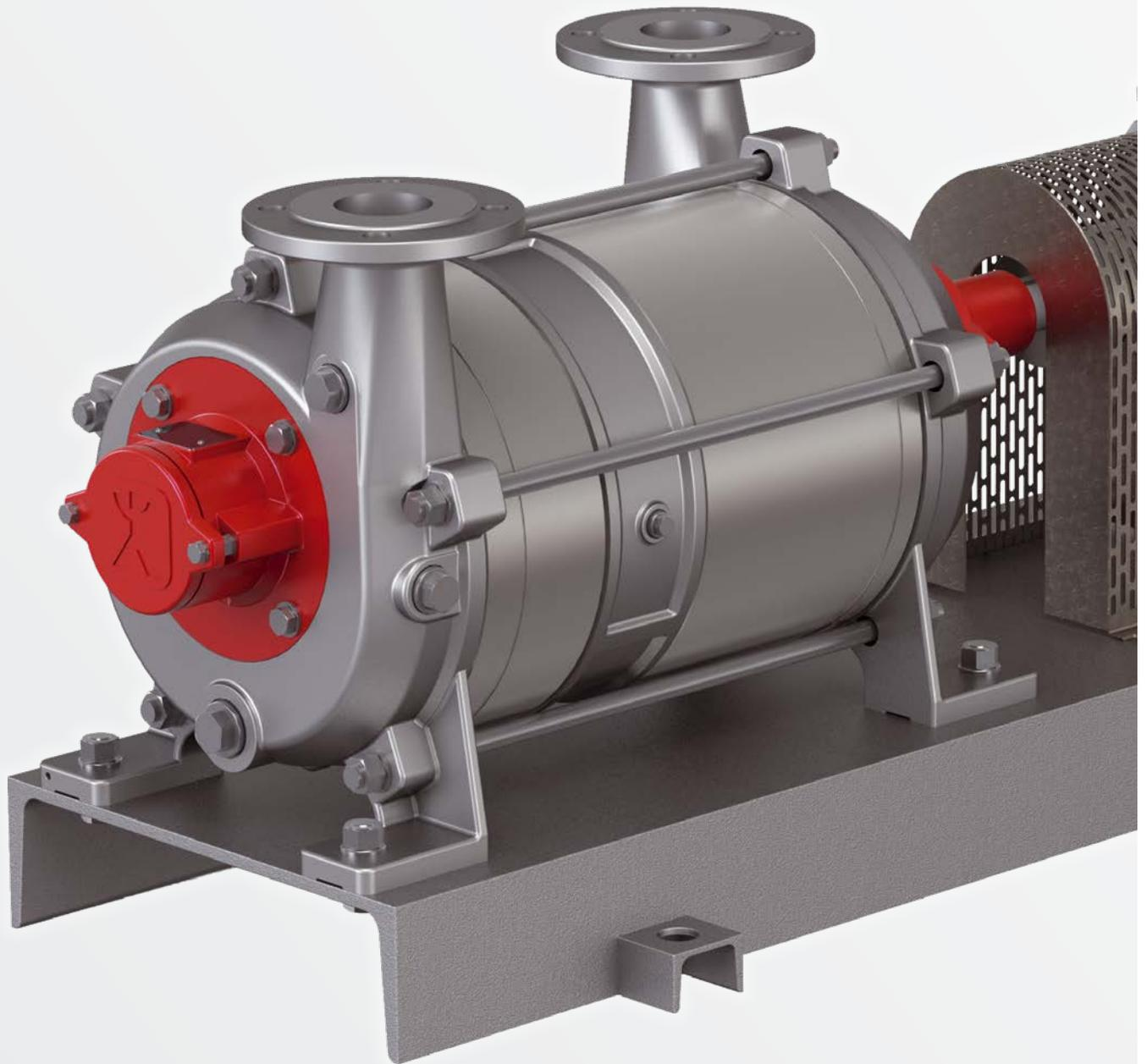

Applications



Food, Beverage and Cosmetics industries

- » Filling bottles with beer, mixed beverages, mineral water and similar
- » Vacuum cutters
- » General processes such as degasification, extraction, suction and vacuum cooking
- » Curing systems
- » Production of sugar and chocolate
- » Production of emulsions and suspensions



Chemical & Pharmaceutical industry

- » Distillation and separation of liquids
- » Recovery of condensates, e. g. solvents
- » Drying of bulk solids, e. g. washing powder, fertiliser, salts, plastic granulates etc.
- » Extraction of liquids, e. g. palm oil



Medical engineering

- » Sterilisation with laboratory and clinical sterilisers



Plastics production and plastics processing

- » Extruder degasification
- » Manufacturing of EPS moulded parts
- » Drying of plastic granulate
- » Decontamination in PET recycling processes

Liquid ring vacuum pumps from Speck

Tailored solutions in modular system

- » Two-stage vacuum pumps
- » Can be used universally for compressing practically all gases and vapours
- » Constant suction performance for different applications
- » Mechanical seal, magnetic coupling or packing gland
- » Application-specific selection of materials like grey cast iron, stainless steel or special alloys
- » ATEX certified

Media	dry and humidified gases
Operating liquid	max. 80 °C
Absorbed gas	dry max. 200 °C saturated max. 100 °C
Minimum inlet pressure	33 mbar abs., 5 mbar abs. with gas ejectors
Flow rate	110 - 1600 m³/h

VHC Series

Two-stage pumps in base plate version



Innovative liquid ring vacuum pumps for universal use

Liquid ring vacuum pumps

are used in many sectors in discontinuous and continuous operation in the three basic processes of extraction, leakage extraction and degasification, for example: extracting dry gases, saturated gases and vapours, extracting contaminated gases

Application-specific benefits

- » Delivering liquid shares at a constant vacuum
- » Delivering explosive gases, e.g. hydrogenous, inflammable or toxic media
- » Oil-free compression, i.e. no oil in the medium nor in the exhaust air
- » Use of the condensed process medium as operating liquid

VHC series - benefits at a glance

Full interchangeability

The VHC series is replacing the previous VH series. The connecting dimensions of the suction and pressure ports, the operating liquid connections, the pump shaft and the pump feet are identical.

Robust bearings

Small spacing of the bearings, lifetime-lubricated deep groove ball bearings

Inter casings in rust-free material

Made from surface-hardened stainless steel for a longer service life

Optimal flushing of the mechanical seal

Pump shaft in stainless steel

For universal use

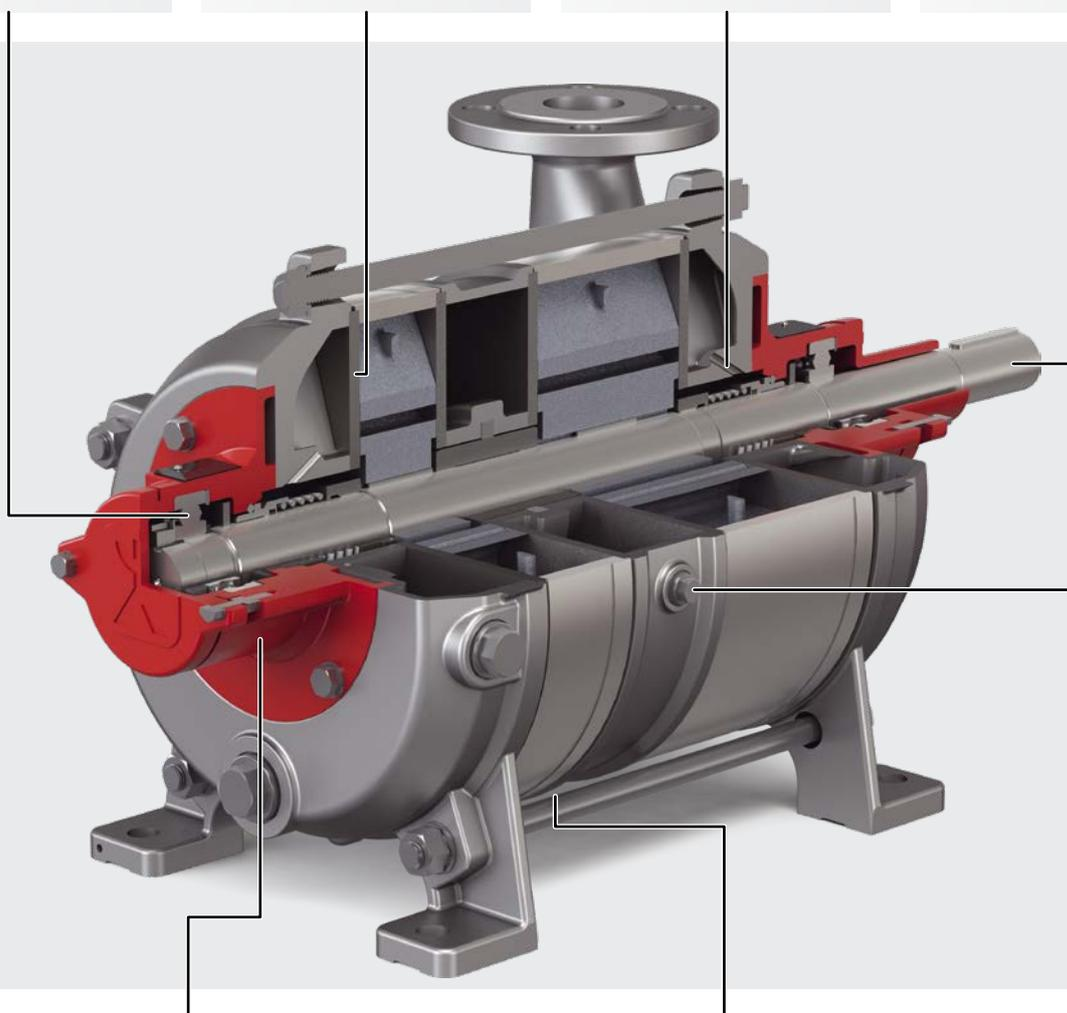

Compact and closed bearing bracket

Simple and fault-free disassembly and assembly without special tools, problem-free setting of the impeller sets

Central drainage

Quick and total drainage of the pump

Pre-set cavitation protection

Safe commissioning and cavitation-free operation

Tailored, long-lasting and service-friendly solution

The VHC series from Speck is the natural development of the established VH series. It was designed taking into account the requirements of our customers. The result is a heavily standardised series, that sets new standards in safety, durability and reliability for your system.

Tailored solution

The VHC series consists of a comprehensive modular system. With easily configurable options and individual special solutions, we fulfil the highest customer requirements and guarantee safe operation.

Mechanical seals

At Speck, you receive a wide range of single and double-action mechanical seals from brand manufacturers with slide rings in A carbon, B carbon, SiC, Cr steel, stainless steel and with O-rings in FKM, EPDM, FFKM, NBR etc.

Magnetic couplings

For applications with toxic, corrosive and combustible media, all sizes are also available in hermetically sealed versions with magnetic coupling. Thanks to the magnetic coupling free from eddy current losses used in the VHC, the power consumption is significantly reduced compared with a conventional magnetic coupling.

Packing glands

The low-cost solution for simple applications with uncritical media.

Application-specific material selection

Speck also offers a wide range of medium-specific pump designs suitable for acids, lyes, hydrocarbons, glycol, glycerine, for example. For the stage sealing, we have a selection of flat gaskets made from various materials, cord packing made from Teflon® or different liquid seals from Epple® and Chesterton® at our disposal.

ATEX / TA Luft (Technical Instruction on Air Quality Control)

The VHC series is type-tested for ATEX in accordance with category 1G (+H2).

The version with magnetic coupling fulfils the strictest requirements of TA Luft (Technical Instruction on Air Quality Control).

Reliable and long-lasting

The solid and compact design, combined with reliable components, guarantees high operational reliability and a significantly extended service life.

The robust and life-time lubricated rolling bearings, improved flushing of the mechanical seals and the surface-hardened inter casings made from stainless material also help to prolong the service life.

The cavitation protection installed in the pump intermediate stage by Speck enables easy commissioning and safe operation without readjustment and performance losses.

The new design of the VHC series also guarantees safe external cleaning and central complete drainage on the product side. The bearing brackets come closed, splash-proof and optionally also rust-free.

Service-friendly

In operation

The VHC series is characterised by low maintenance costs and high system availability. Maintenance-free rolling bearings, hardened stainless steel inter casings without valves and the improved flushing of the mechanical seals reduce the maintenance requirements and the operating costs considerably.

During assembly

Assembly is much easier and kept as simple as possible thanks to the significantly reduced number of components. The proven and simple segment design has been perfected and enables simple and fault-free disassembly and assembly in just a short time.

For spare parts storage

In the consistently designed modular system with 11 sizes, many components are completely interchangeable within a size family. Wear parts like mechanical seals and bearings are identical across several sizes and help to reduce the stored quantities.



VHC in TA Luft design → pages 12 and 13

Characteristic curves VHC0110/0140/0180

50 Hz – 1450 min⁻¹

60 Hz – 1750 min⁻¹

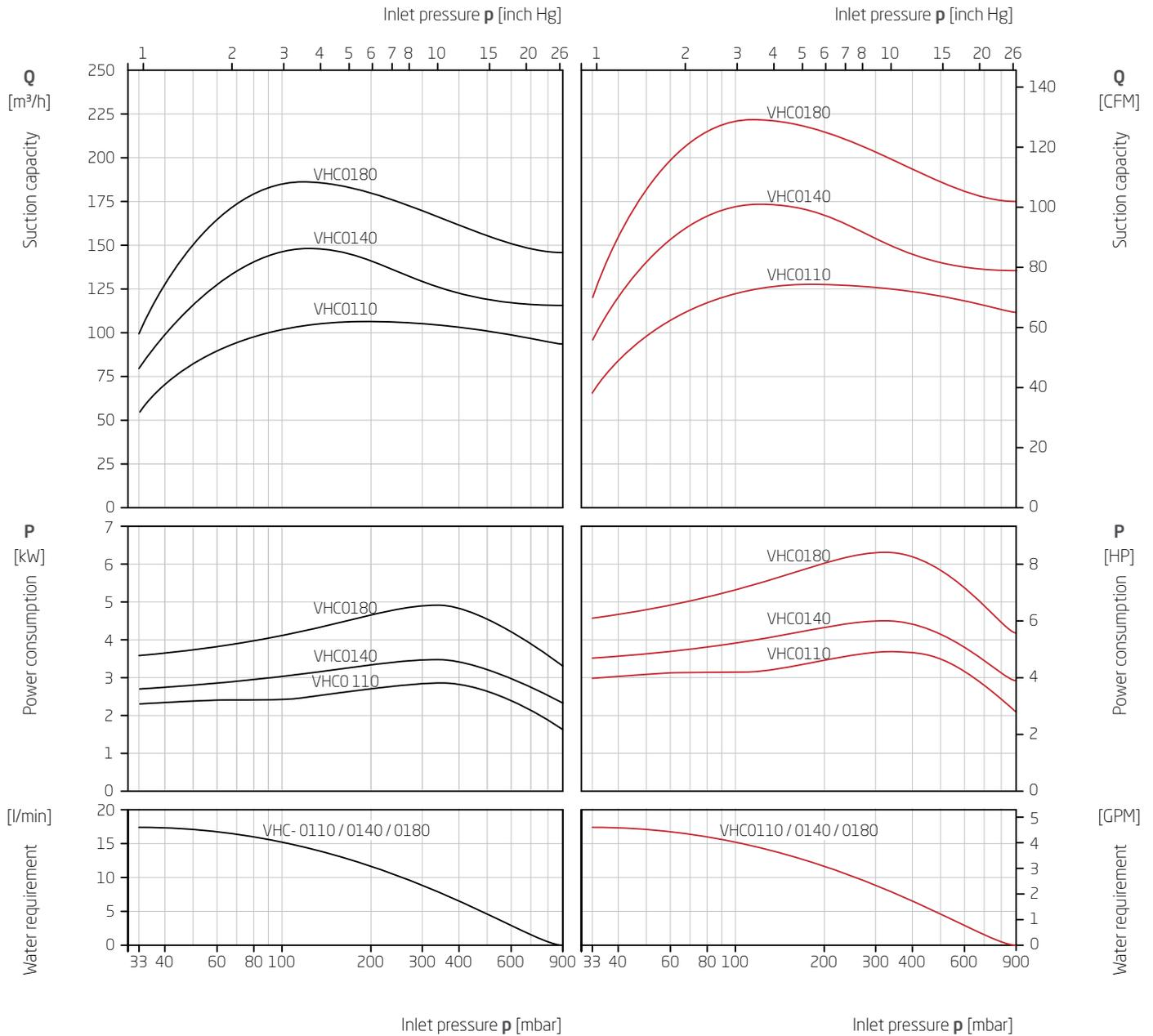

Suction capacity and power consumption depending on inlet pressure

The characteristics are applicable for compression of 20 °C (68 °F) dry air from inlet pressure to atmospheric pressure (1013 mbar / 30 inch Hg a) for nominal speed and drive with three phase motors. Ring liquid is water at 15 °C (59 °F). The tolerance of the suction capacity is -10 % and of the power consumption +10 %.

With different operating conditions characteristic curves change (e.g. differing gas operating liquid conditions, conveying of additional liquids and/or pumping of gas-steam mixtures).

Characteristic curves VHC0300/0350/0400

50 Hz – 1450 min⁻¹

60 Hz – 1750 min⁻¹

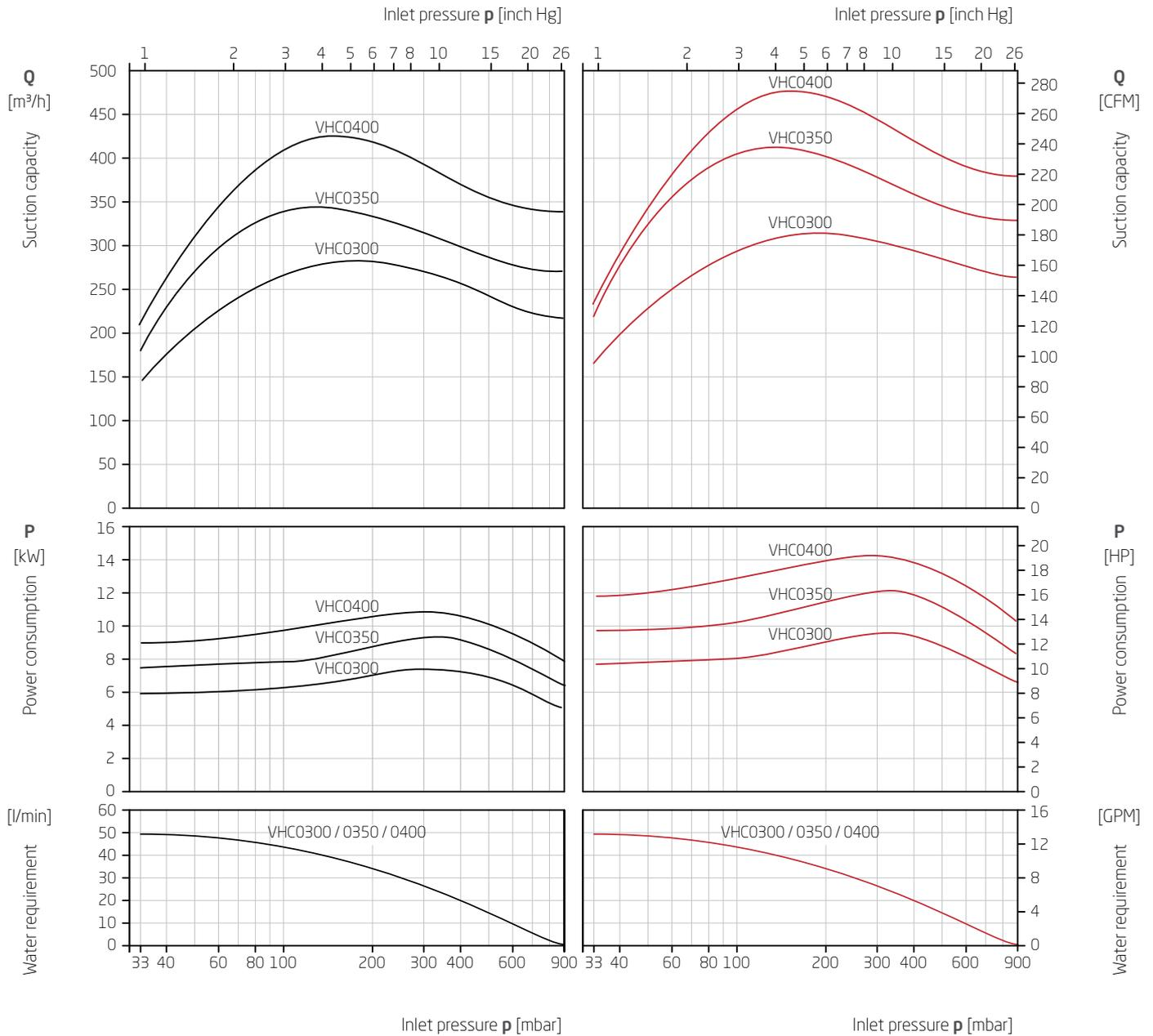

Suction capacity and power consumption depending on inlet pressure

The characteristics are applicable for compression of 20 °C (68 °F) dry air from inlet pressure to atmospheric pressure (1013 mbar / 30 inch Hg a) for nominal speed and drive with three phase motors. Ring liquid is water at 15 °C (59 °F). The tolerance of the suction capacity is -10 % and of the power consumption +10 %.

With different operating conditions characteristic curves change (e.g. differing gas operating liquid conditions, conveying of additional liquids and/or pumping of gas-steam mixtures).

Characteristic curves VHC0500/0600

50 Hz - 1450 min⁻¹

60 Hz - 1750 min⁻¹

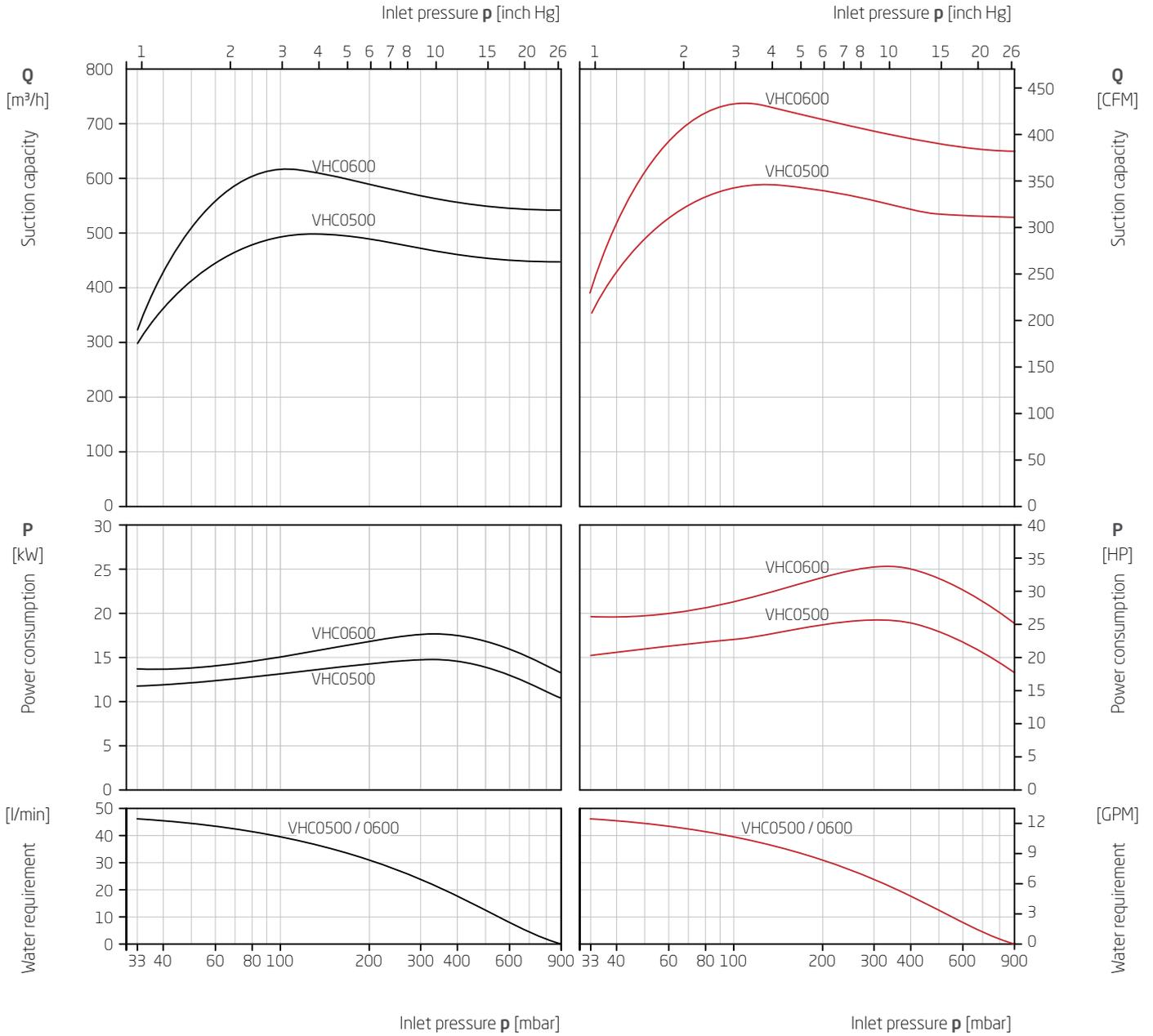

Suction capacity and power consumption depending on inlet pressure

The characteristics are applicable for compression of 20 °C (68 °F) dry air from inlet pressure to atmospheric pressure (1013 mbar / 30 inch Hg a) for nominal speed and drive with three phase motors. Ring liquid is water at 15 °C (59 °F). The tolerance of the suction capacity is -10 % and of the power consumption +10 %.

With different operating conditions characteristic curves change (e.g. differing gas operating liquid conditions, conveying of additional liquids and/or pumping of gas-steam mixtures).

Characteristic curves VHC0800/1200/1600

50 Hz – 975 min⁻¹

60 Hz – 1175 min⁻¹

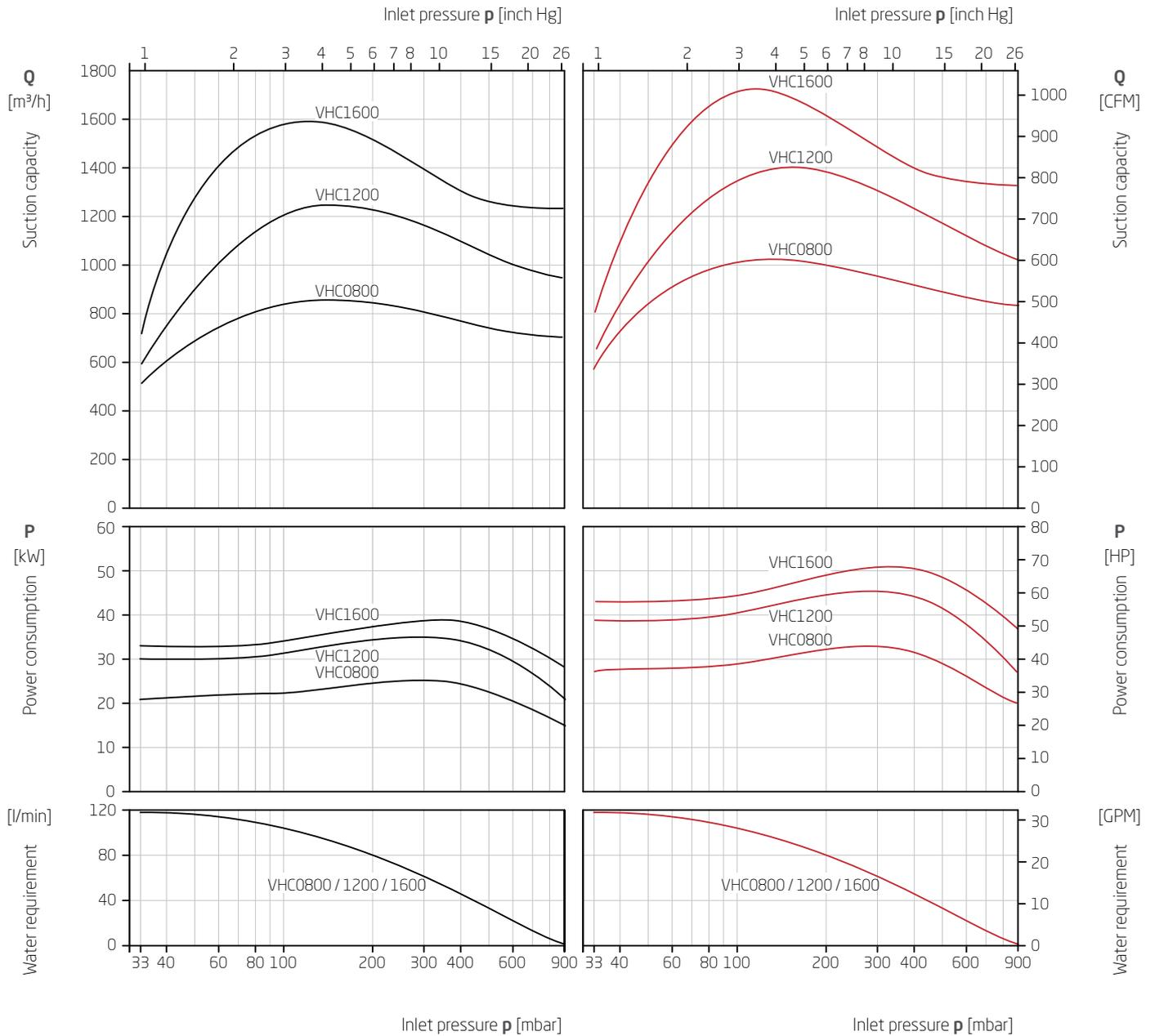

Suction capacity and power consumption depending on inlet pressure

The characteristics are applicable for compression of 20 °C (68 °F) dry air from inlet pressure to atmospheric pressure (1013 mbar / 30 inch Hg a) for nominal speed and drive with three phase motors. Ring liquid is water at 15 °C (59 °F). The tolerance of the suction capacity is -10 % and of the power consumption +10 %.

With different operating conditions characteristic curves change (e.g. differing gas operating liquid conditions, conveying of additional liquids and/or pumping of gas-steam mixtures).

Technical data

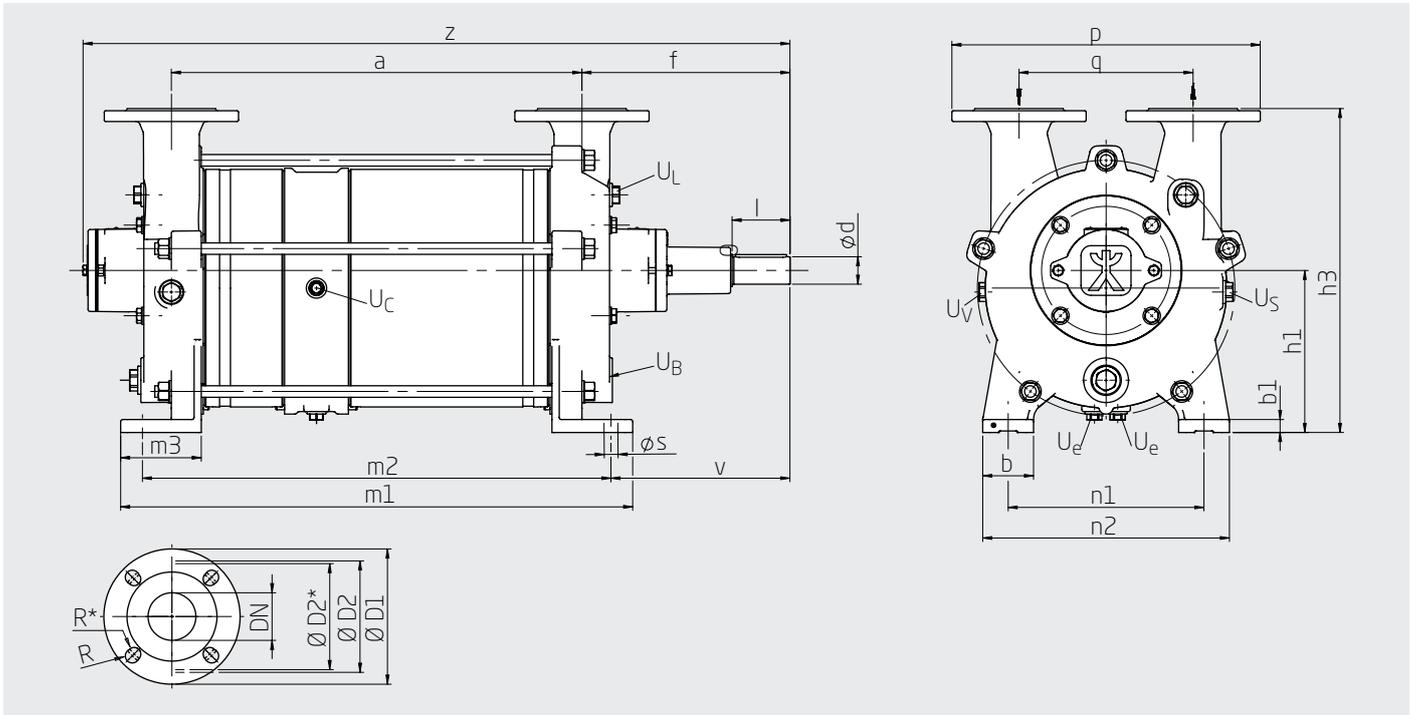

Dimensions

Type	a	b	b1	Ød	DN	f	h1	h3	l	m1	m2	m3	n1	n2	p	q	Øs	v	z
VHC0110	239	50	15	28	40	184	160	320	50	335	298	74	200	250	330	180	15	155	531
VHC0140	269	50	15	28	40	184	160	320	50	365	328	74	200	250	330	180	15	155	561
VHC0180	339	50	15	28	40	184	160	320	50	435	398	74	200	250	330	180	15	155	631
VHC0300	335	60	17	38	50	282	212	402	80	435	385	80	240	300	395	230	19	257	743
VHC0350	375	60	17	38	50	282	212	402	80	475	425	80	240	300	395	230	19	257	784
VHC0400	435	60	17	38	50	282	212	402	80	535	485	80	240	300	395	230	19	257	844
VHC0500	500	70	18	38	65	287	225	450	80	640	580	111	270	340	425	240	19	247	902
VHC0600	566	70	18	38	65	287	225	450	80	706	646	111	270	340	425	240	19	247	968
VHC0800	540	98	21	60	100	422	320	595	140	694	620	123	380	480	590	370	19	382	1131
VHC1200	690	98	21	60	100	422	320	595	140	844	770	123	380	480	590	370	19	382	1281
VHC1600	790	98	21	60	100	422	320	595	140	944	870	123	380	480	590	370	19	382	1381

Weight

Type	kg	lbs
VHC0110	59	130
VHC0140	68	150
VHC0180	77	170
VHC0300	115	254
VHC0350	121	267
VHC0400	140	309
VHC0500	170	375
VHC0600	186	410
VHC0800	406	895
VHC1200	460	1014
VHC1600	530	1168

Connection dimensions

Type	U _B	U _C	U _e	U _L	U _S	U _V
VHC0110	G ½	G ½	G ½	G ½	G ¾	G ¾
VHC0140	G ½	G ½	G ½	G ½	G ¾	G ¾
VHC0180	G ½	G ½	G ½	G ½	G ¾	G ¾
VHC0300	G 1	G ¾	G ¾	G ¾	G ¾	G ¾
VHC0350	G 1	G ¾	G ¾	G ¾	G ¾	G ¾
VHC0400	G 1	G ¾	G ¾	G ¾	G ¾	G ¾
VHC0500	G 1	G ¾	G ¾	G ¾	G ¾	G ¾
VHC0600	G 1	G ¾	G ½	G ¾	G ¾	G ¾
VHC0800	G 2	G ½	G ½	G 1 ½	G ¾	G ¾
VHC1200	G 2	G ½	G ½	G 1 ½	G ¾	G ¾
VHC1600	G 2	G ½	G ½	G 1 ½	G ¾	G ¾

Connection designations

Abb.	Designation
U _B	Connection for operating liquid
U _C	Connection for protection against cavitation
U _e	Connection for drainage
U _L	Connection for ventilation valve
U _S	Connection for sensor
U _V	Connection for drain valve

Flanges

Size	EN 10921 PN 10			ANSI	
	DN	D1	D2	R Ø	D2
40	150	110	18	19.1	98.6
50	165	125	18	19.1	129.3
65	185	145	18	19.1	152.4
100	220	180	18	19.1	190.5

Type codes with seal and materials

	VHC	0600	M	-53	-15	-000
	VHC	0400			-65	-000
Series						
Size						
Design with magnetic coupling						
Mechanical seal (table 1)						
Materials (table 2)						
Counting number						

Table 1: Mechanical seal

Code	41	50	53	55
	Carbon, Cr steel, NBR	Carbon, stainless steel, FFKM	Carbon, stainless steel, FKM	Carbon, stainless steel, FKM double PTFE-coated

Table 2: Materials

Code	15	35	35	35	65
Types	VHC0110 VHC0140 VHC0180 VHC0300 VHC0350 VHC0400	VHC0110 VHC0140 VHC0180 VHC0300 VHC0350 VHC0400 VHC0500 VHC0600	VHC0800 VHC1200	VHC1600	VHC0110 VHC0140 VHC0180 VHC0300 VHC0350 VHC0400 VHC0500 VHC0600 VHC0800 VHC1200 VHC1600
Suction casing, discharge casing, intermediate casing and casing for shaft sealing	EN-GJL-250 Cast iron	EN-GJL-250 Cast iron	EN-GJL-250 Cast iron	EN-GJL-250 Cast iron	1.4581 CrNiMo cast steel
Inter casing	1.4301 CrNi-steel	1.4571 CrNiMo-steel	1.4571 CrNiMo-steel	1.4571 CrNiMo-steel	1.4571 CrNiMo-steel
Stage casing	Steel	Steel	Steel	Steel	1.4581 CrNiMo cast steel
Impellers	CuSn Bronze	1.4581 CrNiMo-cast steel	1.4027 / 1.4308 Cr / CrNi cast steel	1.4027 / 1.0580 Cr cast steel / steel	1.4581 CrNiMo cast steel
Shaft	1.4122 CrMo-Steel	1.4122 CrMo-Steel	1.4122 CrMo-Steel	1.4122 CrMo-Steel	1.4571 CrNiMo-steel

EN-GJL-250 = EN-JL1040 = GG-25 = FGL 250

ⓘ Subject to modifications of materials and errors.

Performance data

Typen	50 Hz				60 Hz			
	power consumption		max. suction capacity	power consumption		max. suction capacity		
	[kW]	[HP]	[m³/h] [CFM]	[kW]	[HP]	[m³/h] [CFM]		
VHC0110	2,9	3,9	107	63	3,7	5,0	128	75
VHC0140	3,5	4,7	145	85	4,5	6,0	174	102
VHC0180	4,9	6,6	186	109	6,3	8,4	223	131
VHC0300	7,3	9,8	283	167	9,5	12,7	314	185
VHC0350	9,3	12,5	342	201	12,1	16,2	411	242
VHC0400	10,9	14,6	425	250	14,2	19,0	475	280
VHC0500	14,5	19,4	501	295	18,9	25,3	590	347
VHC0600	17,6	23,6	616	363	25,1	33,7	739	435
VHC0800	25,8	34,6	862	507	32,7	43,9	1032	607
VHC1200	34,9	46,8	1252	737	45,4	60,9	1407	828
VHC1600	39,2	52,6	1589	935	50,9	68,3	1717	1011

Sizes of the previous VH* series still available

Types	50 Hz				60 Hz			
	power consumption		max. suction capacity	power consumption		max. suction capacity		
	[kW]	[HP]	[m³/h] [CFM]	[kW]	[HP]	[m³/h] [CFM]		
VH0020	0,8	1,1	21	12	1,1	1,5	25	15
VH0040	1,3	1,8	46	27	1,7	2,3	52	31
VH0060	2,0	2,7	56	33	2,6	3,5	68	40

* → Brochure "Vacuum pumps in base plate design - series VZ, VH, VU"

ChemTAL – The VHC version according to TA Luft (Technical Instruction on Air Quality Control)

ChemTAL fulfils all legally specified requirements for air pollution control and offers a wide range of benefits.

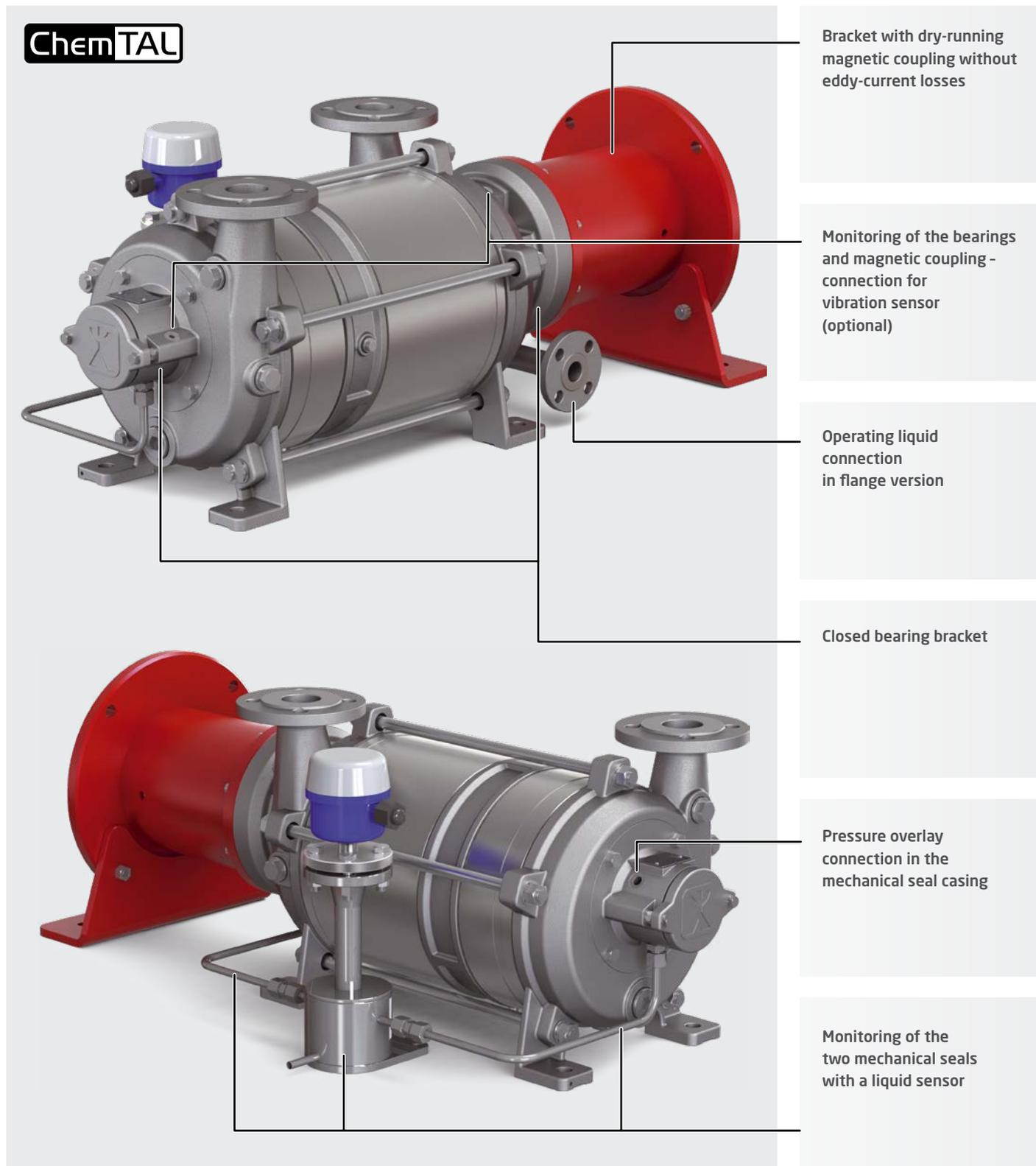

Safe, low lifecycle costs and durable

ChemTAL is the safe and efficient solution when using toxic, corrosive and combustible media.

The design with proven mechanical seals in combination with external rolling bearings and a dry-running magnetic coupling guarantees leak-tightness and safety. The components in contact with the media are made from stainless steel or rust-free special alloys. Various material combinations for the mechanical seals are also coordinated depending on the media to be pumped.

High operational safety

ChemTAL is safe, as the entire pump is hermetically sealed and the requirements of the legally specified TA Luft (Technical Instruction on Air Quality Control) are met.

Several monitoring systems guarantee high availability via early detection of possible wear and identification of unsuitable operating modes. Optional vibration sensors monitor the condition of the ball bearings and the magnetic coupling. The two mechanical seals are monitored by a liquid sensor. An additional nitrogen connection on the bearing brackets enables inertisation of the sealing system.

During the start-up process, ChemTAL is resistant to dry running due to the external bearings. Operating liquids with different viscosities can be used based on the process. If damage occurs on the separating can, the ChemTAL can still be used without problems for a specific time. This means that the pump maintenance can be planned in a targeted way.

All series are type-tested for ATEX to category 1G (+H2)

Low life-cycle costs

ChemTAL requires no seal supply systems, meaning it is extremely service-friendly and is characterised by low maintenance costs.

The magnetic coupling free from eddy current losses used in the VHC results in a tangible energy saving compared with conventional magnetic couplings..

Long-lasting

ChemTAL has a long service life, as lasting solutions from the VHC series are used for wear parts..

Production program

Liquid ring vacuum pumps from Speck



VI Series

The water saver

Single-stage pumps in inverted design with valves flaps and internal water restraining system

50 Hz p_{\min} : 33 mbar abs. / Q_{\max} : 45 m³/h

60 Hz p_{\min} : 33 mbar abs. / Q_{\max} : 55 m³/h



V Series

The all-rounders

Single-stage pumps with valve flaps, close-coupled and bracket versions

50 Hz p_{\min} : 33 mbar abs. / Q_{\max} : 370 m³/h

60 Hz p_{\min} : 33 mbar abs. / Q_{\max} : 445 m³/h



VG Series

Valveless and low-maintenance

Single-stage pumps without valves, free of dead spots, close-coupled and bracket versions

50 Hz p_{\min} : 40 mbar abs. / Q_{\max} : 200 m³/h

60 Hz p_{\min} : 40 mbar abs. / Q_{\max} : 245 m³/h



VE Series

For suction or compression mode

Single-stage pumps with valve flaps, close-coupled version, excentrics on top

50 Hz p_{\min} : 33 mbar abs. / Q_{\max} : 190 m³/h

60 Hz p_{\min} : 33 mbar abs. / Q_{\max} : 230 m³/h



VN Series

For large quantities of additional liquid

Single-stage pumps with valve flaps and port cylinder, close-coupled and bracket versions

50 Hz p_{\min} : 55 mbar abs. / Q_{\max} : 180 m³/h

60 Hz p_{\min} : 55 mbar abs. / Q_{\max} : 215 m³/h



VU Series

Tried-and-tested robust technology for rough vacuum

Single-stage pumps in base plate version

50 Hz p_{\min} : 120 mbar abs. / Q_{\max} : 1550 m³/h

60 Hz p_{\min} : 120 mbar abs. / Q_{\max} : 1900 m³/h



VZ Series

Robust and low-noise technology for deep vacuum ranges - Two-stage pumps without valves, close-coupled and bracket versions, magnetic couplings on request

50 Hz p_{\min} : 33 mbar abs. / Q_{\max} : 185 m³/h

60 Hz p_{\min} : 33 mbar abs. / Q_{\max} : 225 m³/h



VH Series

Tried-and-tested robust technology for deep vacuum ranges - Two-stage pumps in base plate version without valves

50 Hz p_{\min} : 33 mbar abs. / Q_{\max} : 56 m³/h

60 Hz p_{\min} : 33 mbar abs. / Q_{\max} : 68 m³/h



VHC Series

Innovative technology for deep vacuum ranges - Two-stage pumps in base plate versions without valves

50 Hz p_{\min} : 33 mbar abs. / Q_{\max} : 1600 m³/h

60 Hz p_{\min} : 33 mbar abs. / Q_{\max} : 1700 m³/h

Order-related tests



Computer-controlled and fully automated test stands for vacuum pumps on the premises of Speck in Roth. Measuring of hydraulics, power requirements and vibrations. Test of inlet pressures up to 5 mbar and suction capacities up to 2000 m³/h..

Testing the performance

Speck carries out hydraulic tests as standard.

The measurement of the characteristic curves apply to the delivery of water at nominal speed according to DIN 28431.

The tolerance of the suction capacity is -10 % and of the power consumption +10 %. With different operating conditions characteristic curves change (e.g. differing gas operating liquid conditions, conveying of additional liquids and/or pumping of gas-steam mixtures).

Other tests

At the customer's request, Speck offers the following tests:

Hydrostatic pressure test

The hydrostatic pressure test is used to prove strength of the components and that the pump is leak-proof. The fully assembled pump is tested. If you want to use pressure tests according to different criteria, please enter them in the request.

Vibration test

Vibration test according to EN ISO 5199, Edition 2002 – the vibration values are measured radially and vertically at every operating point on the bearing casing at the nominal speed.

Temperature measurement

The measurement is taken on the motor-side bearing at operating temperature. The operating temperature and the ambient temperature at every operating point measured are documented.

Noise measurement

Scope and procedures in close cooperation with the customer

Representations

vertreter / sales
Service / Service

Speck Pumpen Walter Speck GmbH & Co. KG

**Speck Pumpen
Systemtechnik GmbH**
**Speck Pumpen
Vakuumentchnik GmbH**
Regensburger Ring 6 - 8, 91154 Roth
T: +49 9171 809 0
F: +49 9171 809 10
info@speck.de
www.speck.de

Speck Office Nord Ingenieure Willy Wandrach GmbH

Flurstraße 105
22549 Hamburg
T: +49 40 398 624 0
F: +49 40 398 624 28
info@speck-nord.de
www.speck-nord.de

Speck Office Mitte

Grottrian-Steinweg-Str. 1c
38112 Braunschweig
T: +49 531 23 000 90
info@speck-mitte.de
www.speck-mitte.de

Speck Office West

Robert-Koch-Straße 22
40764 Langenfeld
T: +49 2173 914 560
info@speck-west.de
www.speck-west.de

Speck Office Ost

Dahlener Str. 7a
04889 Belgern-Schildau
T: +49 34221 557 812
info@speck-ost.de
www.speck-ost.de

Speck Office Südwest

Frankenstr. 9
67227 Frankenthal
T: +49 6233 354 80 57
info@speck-suedwest.de
www.speck-suedwest.de

IVT-Pumpen GmbH

Zum Wilschfeld 1 A
31749 Auetal
T: +49 5752 929 597
F: +49 5752 929 599
info@ivt-pumpen.de
www.ivt-pumpen.de

FSE Fluid Systems Erfurt

Poeler Weg 6
99085 Erfurt
T: +49 361 550 715 0
F: +49 361 550 715 19
info@fluidsystems.org
www.fluidsystems.org

Vacuum pumps

Arpuma GmbH
Ottostraße 10
50170 Kerpen
T: +49 2273 953 300 0
F: +49 2273 953 300 20
info@arpuma.de
www.arpuma.de

Austria

Tuma Pumpensysteme GmbH
Eitnergasse 12
1230 Wien
T: +43 191 493 40
F: +43 191 414 46
sales@tumapumpen.at
www.tumapumpen.at

Australia

Speck Subsidiary
Speck Industries Pty Ltd.
Unit 2
6 Glory Road
Gnangara WA 6077
T: 1300 207 380
T: +61 8 6201 1286
sales@speckaustralia.com
www.speckaustralia.com

Belgium

*Heat transfer pumps / Pompes pour
fluid thermique*
FLOWMOTION BVBA
Mergelweg 3
1730 Asse
T: +32 2 309 67 13
F: +32 2 309 69 13
info@flowmotion.be
www.flowmotion.be

SPECK - Pompen België N.V.

Bierweg 24
9860 Aalter
T: +32 937 530 39
F: +32 932 500 17
info@speckpompen.be
www.speckpompen.be

Bulgaria

EVROTECH EOOD
ul. Manastirska 54 A
1111 Sofia
T: +359 2 971 32 73
F: +359 2 971 22 88
office@evrotech.com
www.evrotech.com

Switzerland

Speck Subsidiary
Speck Pumpen Industrie GmbH
Bürglenweg 4
8854 Galgenen
T: +41 554 425 094
F: +41 554 425 094
info@speckswitzerland.com
www.speckswitzerland.com

Häny Tec AG

Pumpen-Prozesse-Service
Lättfeld 2
6142 Gettnau
T: +41 62 544 33 00
F: +41 62 544 33 10
contact@haenytec.ch
www.haenytec.ch

MEYER ARMATUREN PUMPEN GMBH

Rigackerstrasse 19
5610 Wöhlen
T: +41 56 622 77 33
F: +41 56 622 77 60
info@meyer-armaturen.ch
www.meyer-armaturen.ch

China

Speck Subsidiary
**Jiashan SPECK PUMPS
Systemtechnik Ltd.**
No. 57, Hong Qiao Rd., Huimin Street
No. 4 Economic Developing Zone,
314100 Jiashan Xian,
Zhejiang Province
T: +86 573 847 312 98
F: +86 573 847 312 88
steveche@speck-pumps.cn
www.speck-pumps.cn

Czech Republic

Sigmat spol s.r.o.
Kosmonautu c.p. 1103/6a
77200 Olomouc
T: +420 585 231 070
F: +420 585 227 072
sigmet@sigmet.cz
www.sigmet.cz

Denmark

Pumpegruppen a/s
Lundtofttegårdsvej 95
2800 Lyngby
T: +45 459 371 00
F: +45 459 347 55
info@pumpegruppen.dk
www.pumpegruppen.dk

Speck Subsidiary

**SPECK BOMBAS INDUSTRIALES,
S.L.U.**
Trafalgar, 53 despacho 6
Centro de Negocios CNAF
46023 Valencia
T: +34 963 811 094
F: +34 963 811 096
M: +34 618 376 241
ventas@speckbombas.es
www.speck.de

France

Speck Subsidiary
Speck Pompes Industries S.A.
Z.I. Parc d'Activités du Ried
4, rue de l'Énergie
B.P. 227
67727 Hoerdex Cedex
T: +33 3 88 68 26 60
F: +33 3 88 68 16 86
info@speckpi.fr

Great Britain

Speck ABC UK Ltd
AreenA House
Flouston Road,
Clworth, Sandbach
Cheshire CW11 3HL
T: +44 1270 75 36 06
F: +44 1270 76 44 29
admin@speck-abc.com
www.speck-abc.com

Greece

SPECK Hellas
Salaminos St. 54
17676 Kallithea
T: +30 210 956 500 6
F: +30 210 957 747 3
grecha@speckhellas.gr

Italy

Centrifugal pumps / Pompe centrifughe
Speck Industries S.r.l
Via Garibaldi, 53
20010 Canegrate (MI)
T: +39 0331 405 805
M: +39 339 16 59 440
info@speckindustries.it
www.speckindustries.it

Vacuum pumps / Pompe per vuoto

Rio Nanta S.r.l.
Via Mauro Macchi, 42
20124 Milano
T: +39 028 940 642 1
F: +39 028 323 913
M: +39 339 658 781 6
nionanta@nionanta.it
www.nionanta.it

Israel

Hamenia Pumps
7 Beit Alpha St.
Tel-Aviv 6721907
T: +972 356 220 11
F: +972 356 218 43
sales@hameniaumps.com
www.hamenia.co.il

Small pumps / heat transfer pumps

Ringel Brothers (1973) Ltd.
134 Hertzl St.
P.O. Box 5148
Tel-Aviv 66555
T: +972 368 255 05
F: +972 368 220 41
M: +972 544 623 095
rmingel@ringel-bros.co.il
www.ringel-bros.co.il

India

Flux Pumps India Pvt. Ltd.
427/A-2, Guitedi Industrial Estate
Near Prabhat Printing Press
Pune - 411 047, Maharashtra
T: +91 020 2427 1023
F: +91 020 2427 0689
M: +91 98504 03114
kiran.kadam@flux-pumps.in
www.flux-pumps.in

Japan

Speck Subsidiary
Speck Japan Co. Ltd.
Daisho Bldg. 3F,
2-1-16 Kyomachibori, Nishi-ku
550-0003 Osaka
T: +81 6 6486 9633
F: +81 6 6486 9643
info@speckjapan.com
www.speckjapan.com

Speck Subsidiary

Speck Japan Co. Ltd.
Tokyo Branch
No. 408, 3-22-12
Higashi-Ikebukuro, Toshima-ku
170-0013 Tokyo
T: +81 3 5979 8818
F: +81 3 5979 8817
info@speckjapan.com
www.speckjapan.com

Heat transfer pumps / Pompes pour fluid thermique

FLOWMOTION BVBA
Mergelweg 3
1730 Asse
T: +32 2 309 67 13
F: +32 2 309 69 13
info@flowmotion.be
www.flowmotion.be

Malaysia

Leesonmech
Engineering (M) Sdn. Bhd.
No. 18 Jalan 18, Taman Sri Kluang,
86000 Kluang, Johor
T: +607 777 105 5
F: +607 777 106 6
sales@leesonmech.com
www.leesonmech.com

Norway

PG Flow Solutions AS
P.O.Box 154, 1378 Nesbru
Nye Vakaas Vei 14
1395 Hvalstad
T: +47 667 756 00
F: +47 667 756 01
post@pg-flowolutions.com
www.pg-flowolutions.com

Netherlands

*Centrifugal pumps /
Centrifugaalpompen*
Speck Pumpen Nederland B.V.
Businesspark 7/Poort
Stationspoort 10
6902 KG Zevenaar
T: +31 316 331 757
F: +31 316 528 618
info@speck.nl
www.speck.nl

Vacuum pumps / Vacuumpompen

INDUVAC B.V.
Cobaltstraat 16
2711 RM Zoetermeer
T: +31 793 633 890
F: +31 793 633 899
info@induvac.com
www.induvac.com

Heat transfer pumps / Pompes pour fluid thermique

FLOWMOTION BVBA
Mergelweg 3
1730 Asse
T: +32 2 309 67 13
F: +32 2 309 69 13
info@flowmotion.be
www.flowmotion.be

New Zealand

Speck Subsidiary
Speck Industries Pty Ltd.
Unit 2
6 Glory Road
Gnangara WA 6077
T: +61 8 6201 1286
sales@speckaustralia.com
www.speckaustralia.com

Portugal

Ultra Controllo
Projectos Industriais, Lda.
Quinta Lavi - Armazém 8
Abrunheira
2710 - 089 Sintra
T: +351 219 154 350
F: +351 219 259 002
info@ultra-controllo.com
www.ultra-controllo.com

Poland

**Krupinski Pompy Spółka z
Ograniczoną Odpowiedzialnością Sp.K.**
Przymiarki 4A
31-764 Krakow
T + F: +48 126 455 684
biuro@krupinski.krakow.pl
www.krupinski.krakow.pl

Taiwan

Speck Subsidiary
**Speck Pumps
Technology Taiwan Ltd.**
2Fl., no. 153, Sec. 2
Datong Rd., Xizhi District
New Taipei City
T: +886 286 926 220
F: +886 286 926 759
M: +886 936 120 952
speck886@ms32.hinet.net
www.speck-pumps.com.tw

Chile

W & F Ingenieria Y Maquinas S.A.
Felix de Amesti 90, Piso 6
Las Condes, Santiago
T: +56 2 220 629 43
F: +56 2 220 630 39
M: +56 9 8 289 222 0
rwendler@wyf.cl
www.wyf.cl

PT Roda Rollen Indonesia

**Kompleks Pertokoan Glodok
Jaya No. 30**
Jl. Hayam Wuruk,
Jakarta - Pusat
Indonesia, 11180
T: +6221 659 922 528
F: +6221 380 595 9
rudy@rodarollenindonesia.com

ROK Korea

J.C. International Inc.
2F, Bikeum Bldg. 108,
Yanghwa-Ro, Mapo-Gu,
121-893 Seoul
T: +82 232 628 00
F: +82 232 569 09
jylee@jicint.co.kr
www.jicint.co.kr

Romania

S.C. Gimsid S.R.L.
Str. Arcului nr. 9, Arp.2
021031 Bucuresti
T: +40 21 2118701
F: +40 21 2102675
gimsid@gimsid.ro
www.gimsid.ro

Russia

LLC Firm Kreoline
Yunosti str., 5/3
Moscow 111395
T: +7 495 737 321 4
F: +7 495 769 844 0
M: +7 495 505 198 8
info@kreoline.ru
www.kreoline.ru

Sweden

Hugo Tillquist AB
P.O.Box 1120
16422 Kista
T: +46 859 463 200
F: +46 875 136 95
info@tillquist.com
www.tillquist.com

Slovakian Republic

→ Czech Republic (CZ)

Slovenia

SLOTEH Branko Gabric s.p.
Zagrebska cesta 20
2000 Maribor
T: +38 624 614 460
F: +38 624 614 465
branko.gabric@amis.net
www.sloteh.si

Singapore

→ Malaysia (MAL) Engineering (M)
Sdn. Bhd.

LUKES MARINE ENGINEERING & CONSULTING SERVICES PTE LTD

150 Cecil Street no. 03-00
Singapore 069543
T: +65 8379 9051
M: +65 8437 9846
tonylukes@speckpumpssing.com.sg

Thailand

Speck Subsidiary
FLUX-SPECK Pump Co., Ltd
181/4 Soi Anamai
Srinakarin Road
Suanlukang Bangkok 10250
T: +662 320 256 7
F: +662 322 248 6
thienchai@fluxspeck.com
www.fluxspeck.com

Turkey

Speck Pompa
San. ve Tic. Ltd. Sti.
Girne Mah. Kücükalyi Is Merkezi
B Blok No.12 Maltepe
34852 Istanbul
T: +90 216 375 750 5
F: +90 216 375 753 3
M: +(90) 532 293 010 4
speck@speckpompa.com.tr
www.speckpompa.com.tr

USA

Speck Subsidiary

Speck Industries LP
400 Meadow Lane
Carlstadt
NJ 07072
T: +1 201 569 3114
F: +1 201 569 9607
info@speckamerica.com
www.speckamerica.com